

CS603: Distributed Systems

Lecture 22: Anonymity Systems and Traffic Analysis

Needs for Anonymity

- Hiding Identity
 - Sensitive issues, political reasons, secret operations
 - Freedom of speech
- Privacy
 - Human right, corporation benefits
 - Against surveillance, private information tracking and profiling
- Security
 - Hiding actual servers, existence of virtual private network
 - Transfer or “load-balance” attacks to some other relays
- Anonymity offers certain degree of innocence or deniability to an action.

Where is Anonymity Useful?

- Anonymous bulletin board and email
- Electronic voting
- Incident reporting
- Anonymous e-commerce
- Private information retrieval
- Anonymous communication

Anonymity and other Security Services

- Data Confidentiality
 - Encryption schemes (symmetric, public-key)
- Data Integrity
 - Secure Hashing, HMAC
- Authentication
 - Digital signature, certificate authorities, Kerberos
- Data confidentiality + data integrity + authentication
not enough to guarantee anonymity

Anonymity Metrics in Communication

- Basic metrics:
 - **Sender anonymity** - who sends what
 - **Receiver anonymity** - who receives what
 - **Unlinkability** (relationship anonymity) - who talks to whom
- Providing sender anonymity and unlinkability are desirable enough for common Internet activities
- Goals of a potential solution:
 - The identities of the communicating parties should stay anonymous to the outside community
 - Even the parties in communication may not know each other's real identity

Anonymity Systems

Anonymity Set

- Hiding one's action in many others' actions
- **Anonymity set** - a group of users in which every one is equal-probable to be associated with a given action
 - every one has certain degree of innocence or deniability to an action

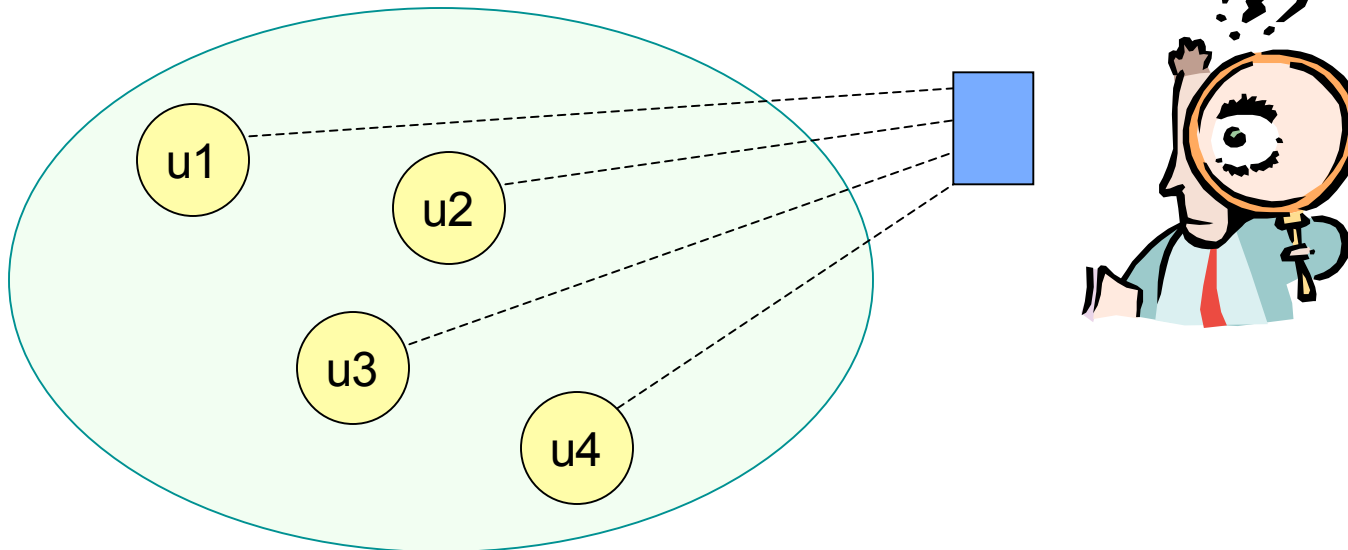

MIX-based Systems

- Concept of using relay servers (MIXes) for anonymous communication
- Introduced by David Chaum (1981)
- Goals
 - Sender anonymity
 - Unlinkability against global eavesdroppers
- **Main idea: Messages from sender “look” (contents, time) differently than messages to recipient**

MIX - Basic Operations

- A mix is a **store-and-forward** relay
- Batching
 - collect fixed-length messages from different sources
 - accumulate a **batch** of n messages
- Mixing
 - **cryptographically transform** collected messages
 - forwarding messages to their recipients in **random order**

MIX - Example

- Each mix has a public key
- Each sender encrypts its message (with randomness) using public key of mix

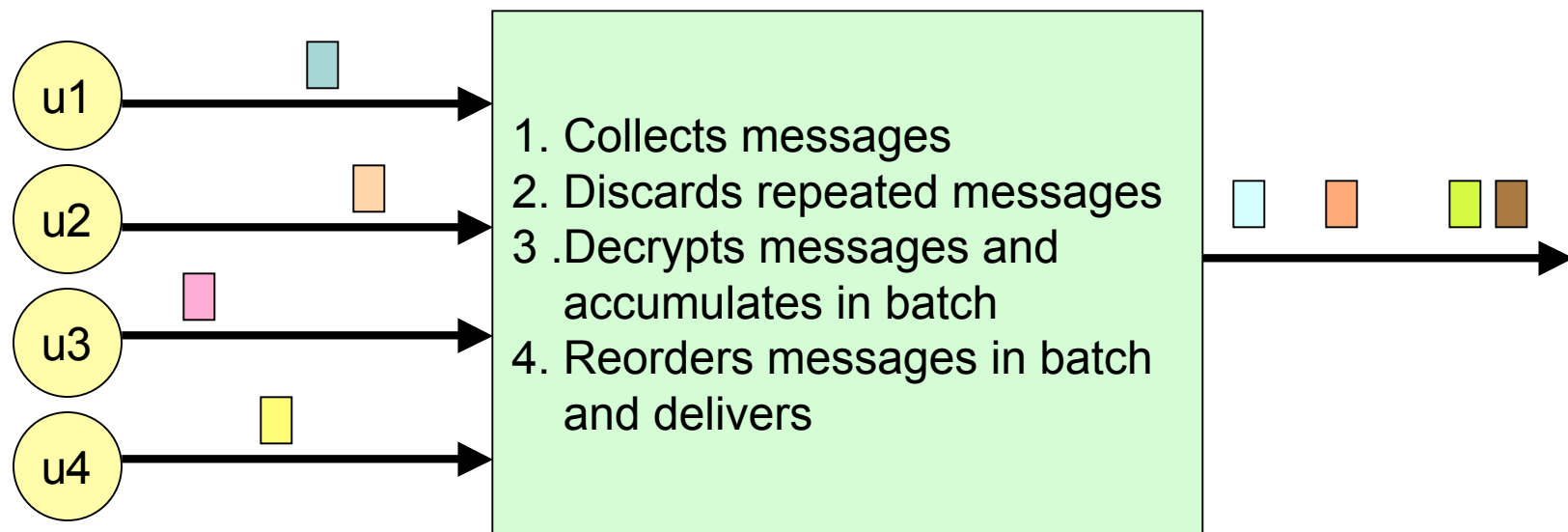

Mix

MIX - Variants

- Single mix (also single point of trust, attack and failure)
- Mix cascade
- Mix network
- Different ways of batch and mix operations

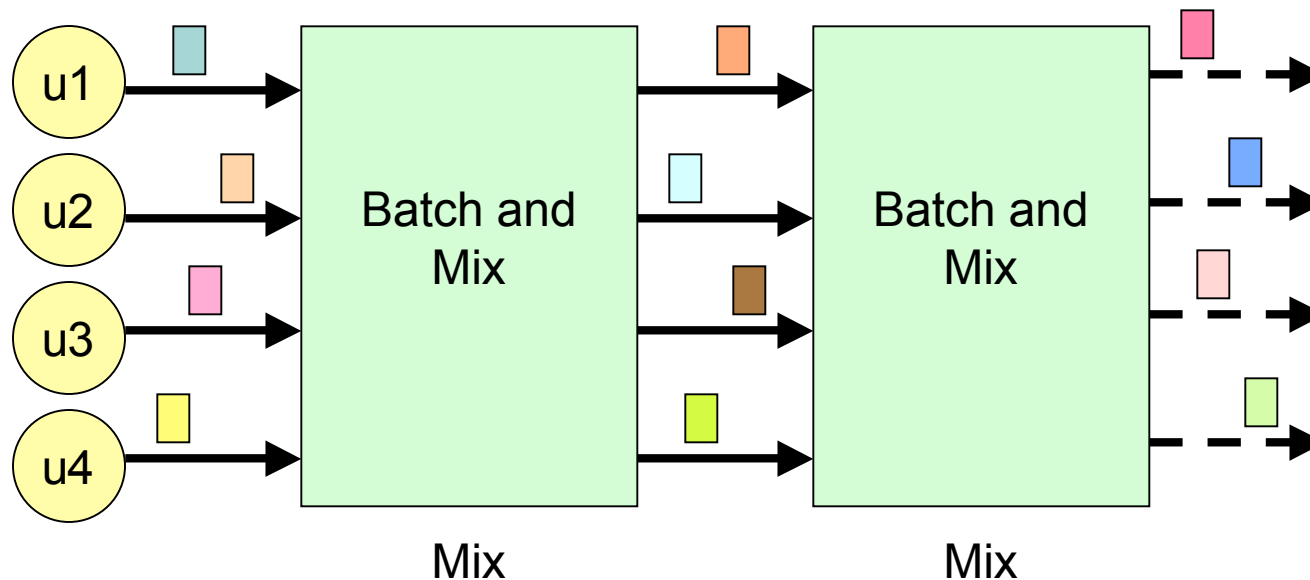

MIX Characteristics

- Traditional designs are **message-based**
- Usually **high latency** and **asynchronous** due to batch and mix operations
 - may be acceptable for applications like email
 - frustrating user experience in low latency or interactive applications: web browsing, instant messaging, SSH
- Alternatives: **circuit-based** designs

Crowds

- Anonymous web browsing
- Dynamic collecting users in a group (*crowd*)
- Member list maintained in a central server (*blender*)
- M. Reiter and A. Rubin 1999

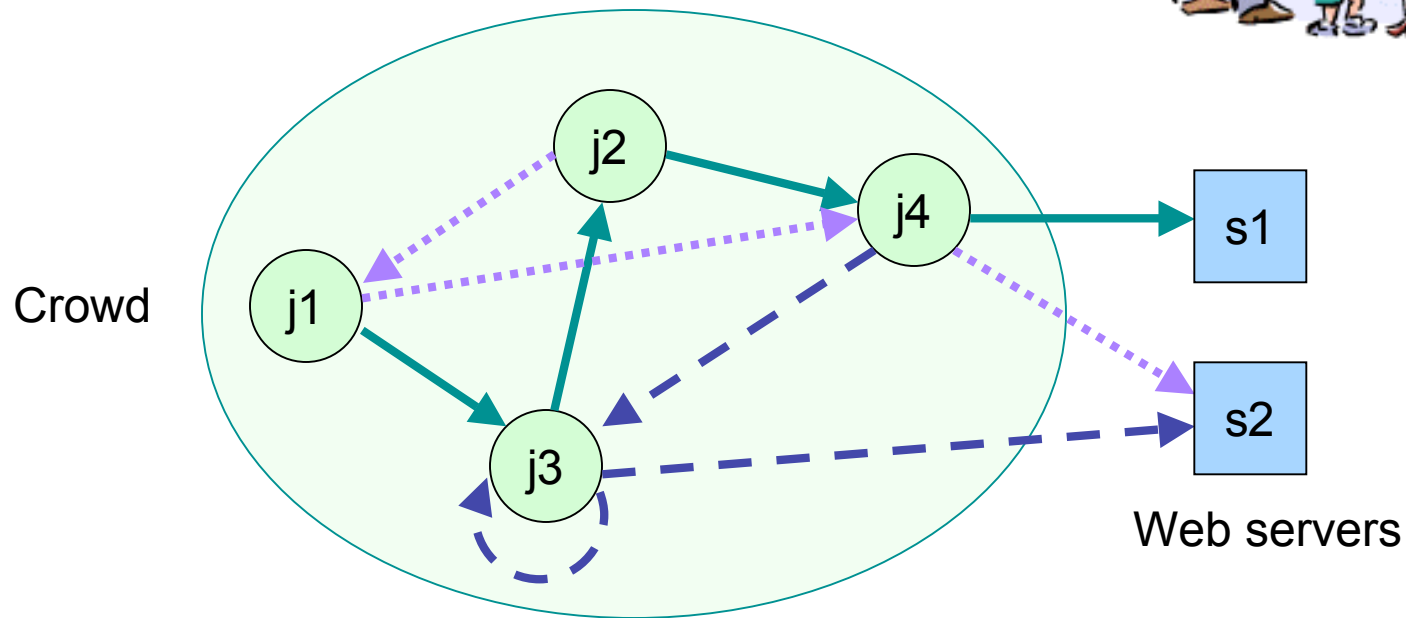

Crowds (cont.)

- Initiator submits request to a **random member**
- Upon receiving a request, a member either:
 - forwards to another random member (**$p = p_f$**)
 - submits to end server (**$p = 1 - p_f$**)
- A random path is created during the first request, subsequent requests use the same path;
- Server replies using the same path but in reverse order
- **Link encryption** of messages with a **shared key** known to all members

Onion Routing

- <http://www.onion-router.net/>
- A (small) fixed core set of relays
 - **Core Onion Router (COR)**
- Designed to support low-latency service
- Initiator defines an anonymous path for a connection through an “onion”
- An **onion** is a layered structure (recursively encrypted using public keys of CORs) that defines:
 - path of a connection through CORs
 - properties of the connection at each point, e.g. cryptographic algorithms, symmetric keys



Onion Routing (cont.)

- Initiator's onion proxy (OP)
 - connects to COR
 - initiates a random circuit using an onion
 - converts data to **fixed size cells**
 - performs **layered encryption**, one per router
- Circuit-based multi-hop forward
 - Each COR decrypts and removes a layer of received cells, then forwards to next COR

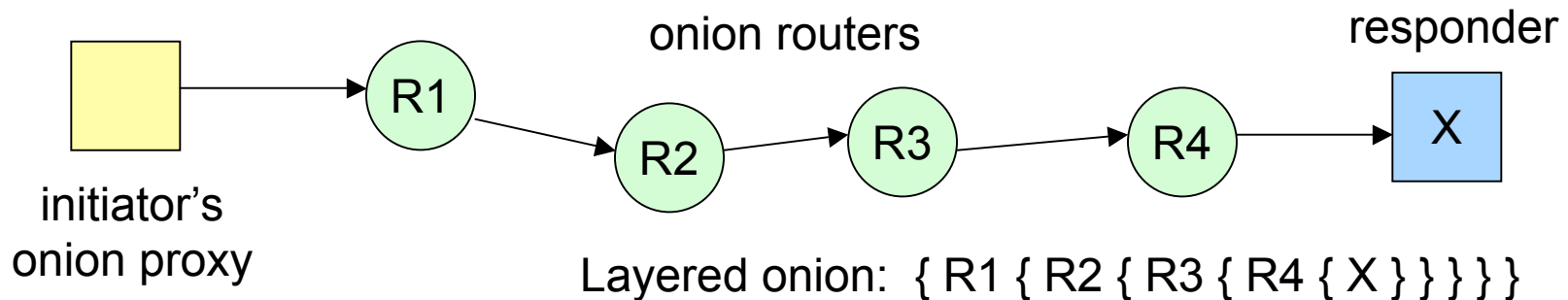

Tarzan & MorphMix

- Similar to Onion routing, Mix-net approach but extended to **peer-to-peer** environment
 - Again, layered/nested encryption with multi-hop forwarding
- All peers are potential message originators and relays
 - More potential relays than a small fixed core set
 - More scalable
 - Hide one's action in a large dynamic set of users
- Tarzan targets at network layer while MorphMix runs at application layer

Tarzan & MorphMix (cont.)

- Larger dynamic set of **unreliable** nodes
- More efforts to defense against **colluding nodes** (dishonest or adversary controlled)
 - Restricted peer-selection in Tarzan
 - Collusion detection mechanism in MorphMix

Traffic Analysis

Attacks on Anonymity Systems

- Degrading the quality of anonymity service
 - Break sender/receiver anonymity, unlinkability
 - Control anonymity to certain level
 - Traffic analysis, traffic confirmation
- Degrading the utilization of anonymity system
 - Decrease the performance, reliability and availability of system, so as to drive users not using the service
 - Denial-of-Service attacks

Traffic Analysis

- If one's interested in breaking the anonymity ...
- Based on features in communication traffic, one may infer
 - who's the initiator □ NO sender anonymity
 - who's the responder □ NO receiver anonymity
 - an initiator-responder mapping □ NO unlinkability

Adversary Types

- **Passive**: eavesdrop traffic
- **Active**: able to observe, delay, alter and drop messages in the system
- **Local**: able to observe traffic to/from user's network link, within LAN
- **Global**: able to observe effectively large amount or all network links, across LAN boundaries
- **Internal**: participants in the anonymity system, adversary-operated nodes
- **External**: not participate in the protocol but may be able to observe, inject or modify traffic in the system

Common Vulnerabilities

- **Message features**
 - distinguishable contents, size
- **Communication patterns**
 - user online/offline period
 - send-receive sequence
 - message frequencies, e.g. burst stream
- **Properties/constraints in anonymity systems**
 - low-latency requirement
 - link capacity and traffic shaping

Attacks on Message Features

- If a message itself reveals one's identity or more, anonymity is defeated regardless of the strength of an anonymity system!
- Message features
 - size, format, writing style ..., etc
- Message size
 - Varieties of message sizes may help linking a message to some application or sender
 - Fixed by constant-size message padding

Distinguishable Message Contents

- Message contents
 - may expose user information or the route of a message
 - e.g. host information, Referrer, User-Agent fields in HTTP header
- Active adversary can perform **message tagging attack**
 - Alter bits in message header/payload
 - Recognize altered messages to exploit the route
- Solutions
 - Proper message transformation: e.g. encryption
 - Removal of distinguishable information: e.g. Privoxy (privacy enhancing proxy)

Packet Counting Attack

- Count the number of messages entering a node and leaving an anonymous tunnel
- Proposed solution: constant link padding:
 - Two nodes exchange a constant number of same-sized packets per time unit
 - Generate dummy traffic on idle or lightly loaded links
 - Costly
 - Still vulnerable to other attacks, e.g. latency attacks

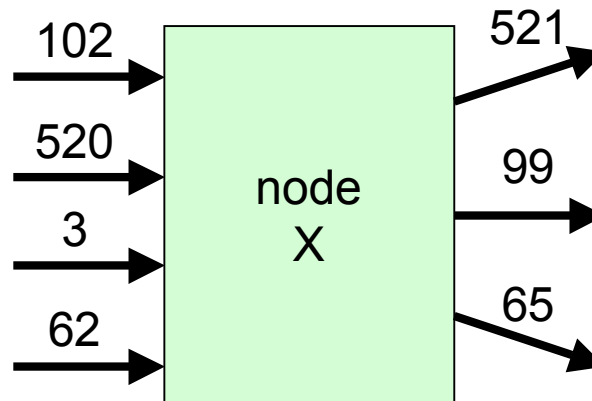

Clogging Attack

- Observe traffic between a certain last node C and end receiver R
- Create a route through a set of suspected nodes
- Clog the route with high volume of traffic
- Decrease in throughput from C to R may indicate at least one node in the suspected route belongs to a route containing C
- Continue with different sets of nodes until a route to R is revealed

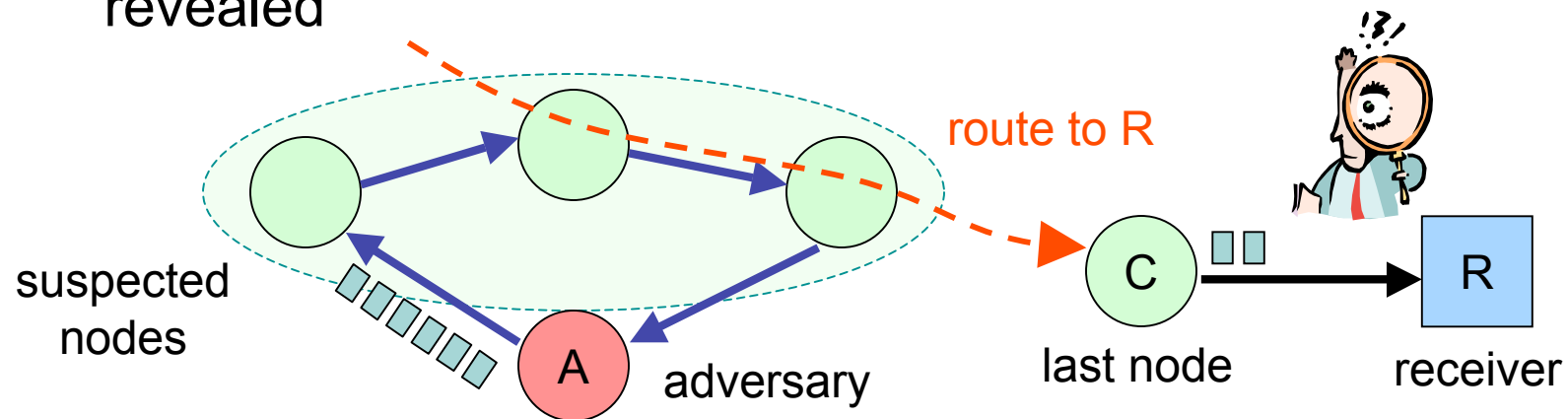

Intersection Attacks

- Communication pattern
 - Users join and leave the system from time to time
 - Users are **not active** in communication all the time
 - Some receivers receive messages after some senders transmit messages
- Intersecting sets of possible senders over different time periods \square anonymity set shrinks
- Short term vs Long term

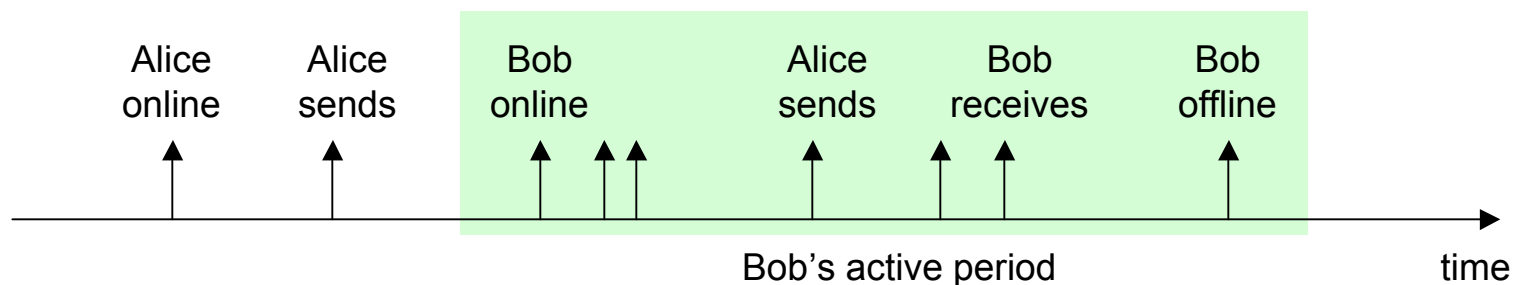

Partition Attack on Client Knowledge

- Render **inconsistent views** of anonymity system on clients
 - e.g. member list on directory server
- Identify clients who always choose a particular subset of neighbors

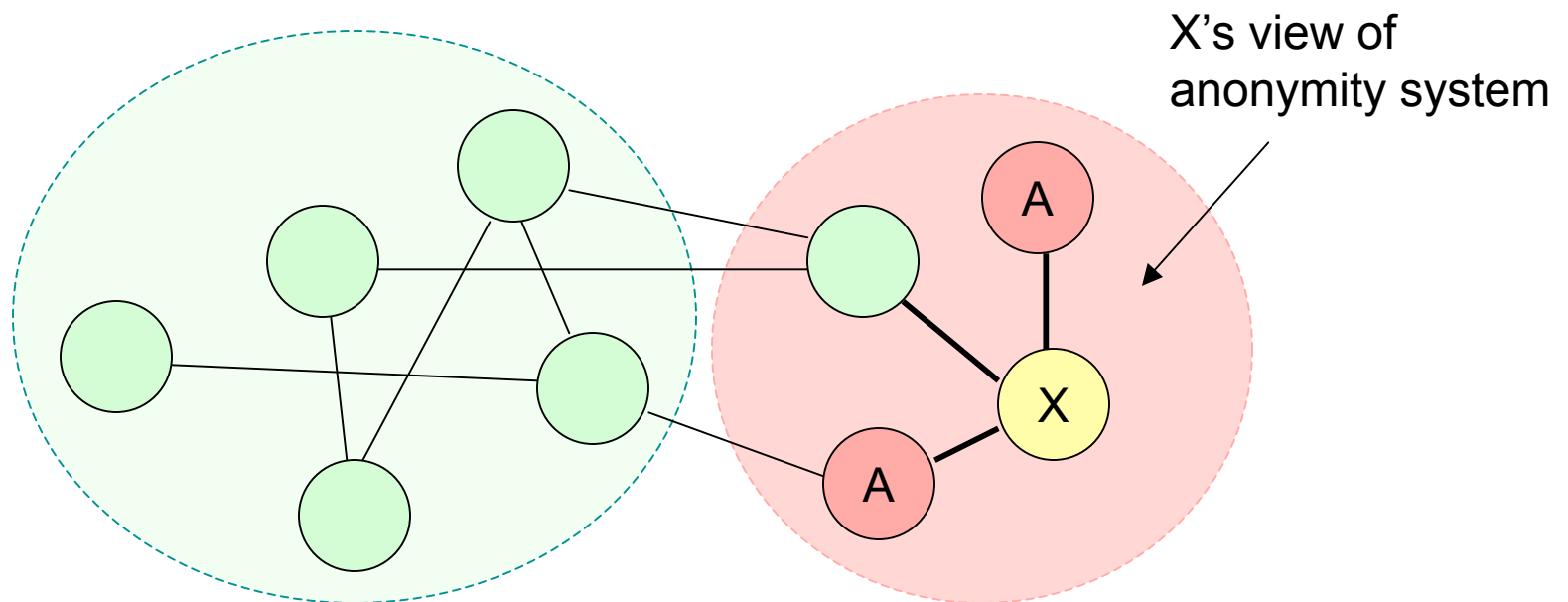

Attacks on Endpoints

- Referred also as **traffic confirmation**
- Suppose an adversary controls the first and the last node of a route
- Observe the traffic entering the first node and leaving the last node

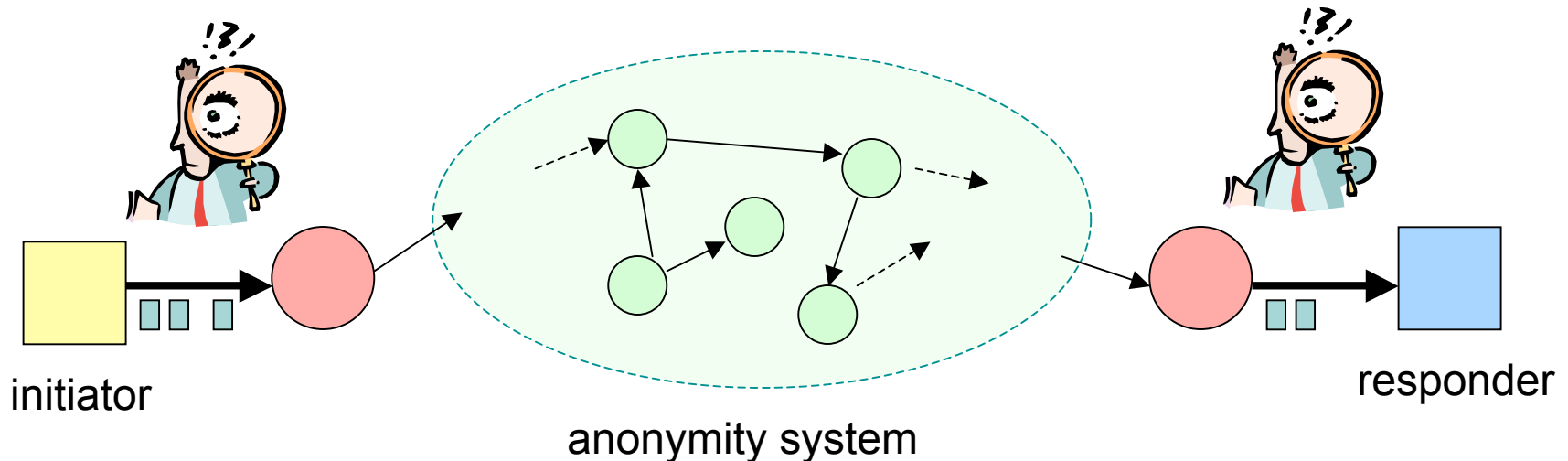

Attacks on Endpoints (cont.)

- Correlate the timings of a message entering the first node with those coming out of the last node
 - Packet counting attack, **Timing attacks**, Message frequency attack
- An adversary may be able to:
 - figure out some input message to output message mappings
 - rule out some potential senders or receivers from the anonymity sets
 - link a particular pair of sender and receiver
- An active adversary may increase the chance of success and speedup the analysis by delaying and dropping messages, flooding several nodes and links

Node Flushing Attack

- Intended to defeat MIX-based systems
- Flooding attack, (n-1) attack
- Flood a node with identifiable fake messages but leave a room for a single message to be traced
- Link user's input message with messages leaving the node

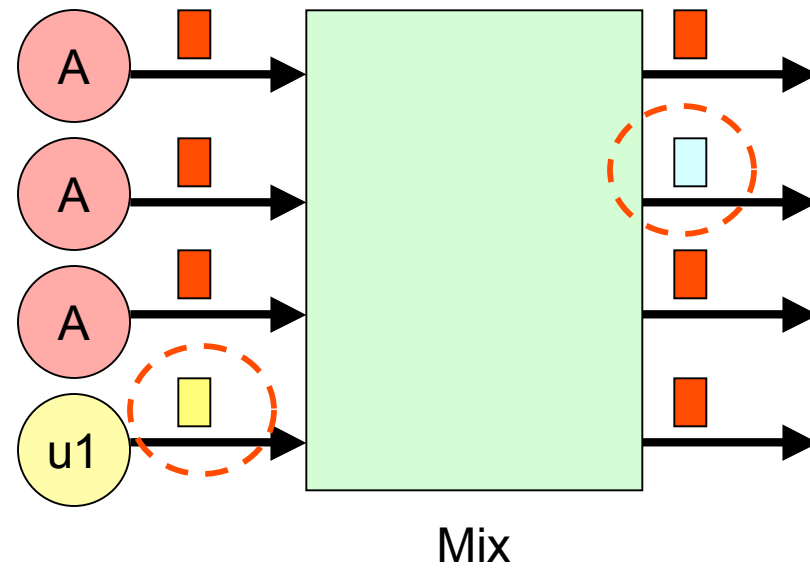

Trickle Attack

- Trickle, flushing attack - referred as blending attack
- Suppose a MIX accumulates and emits messages in rounds
- An active attacker holds a target message until the mix emits a batch of messages
- He then submits target message to mix while blocking other incoming messages
- Only the target message is emitted in the next round
- Requires control over traffic flow - practical to launch?

More Attacks ...

- The “Sting” Attack
- The “Send n’ Seek” Attack
- Active Attacks Exploiting User Reactions
- Denial of Service Attack
- Social Engineering

- Alternative attack goal:
 - Drive users to less secure anonymity systems or not using anonymity service at all

Open Questions

- More users (relays) means better?
 - P2P approaches - more scalable?
 - high dynamicity can be good or bad
 - prevent adversaries from signing up many colluding nodes
- Every traffic should look the same?
 - cover traffic? Constant link padding?
 - effectiveness and performance
- It's a matter of tradeoff!

References

- Jean-François Raymond. **Traffic Analysis: Protocols, Attacks, Design Issues, and Open Problems.** *In the Proceedings of Designing Privacy Enhancing Technologies: Workshop on Design Issues in Anonymity and Unobservability*, July 2000, pages 10-29.
- Adam Back, Ulf Möller, and Anton Stiglic. **Traffic Analysis Attacks and Trade-Offs in Anonymity Providing Systems.** *In the Proceedings of Information Hiding Workshop (IH 2001)*, April 2001, pages 245-257.
- Michael Reiter and Aviel Rubin. **Crowds: Anonymity for Web Transactions.** *In ACM Transactions on Information and System Security*, June 1998

References

- Michael J. Freedman and Robert Morris. **Tarzan: A Peer-to-Peer Anonymizing Network Layer**. *In the Proceedings of the 9th ACM Conference on Computer and Communications Security (CCS 2002)*, Washington, DC, November 2002.
- Marc Rennhard and Bernhard Plattner. **Introducing MorphMix: Peer-to-Peer based Anonymous Internet Usage with Collusion Detection**. *In the Proceedings of the Workshop on Privacy in the Electronic Society (WPES 2002)*, Washington, DC, USA, November 2002.
- **Onion Routing**. <http://www.onion-router.net/>